

Hydraulic Training Systems

Teaching and learning hydraulics in real-time



MF200-CAV Pump Cavitation Simulator

The MF200-CAV gives credence to the term:
“What students see they totally understand”

You can spend hours trying to explain to students what cavitation is and when you're done they'll still probably be doubtful, or you can turn on the totally transparent MF200-CAV and erase all doubt.

Wouldn't it be satisfying to know that when the cavitation lesson is over, your students will KNOW, and more importantly UNDERSTAND, everything that is good and bad about the operation at the inlet side of a pump?

The Good-

Students will learn what is good for a pump:

- How the inlet side of a hydraulic pump works.
- Variables that have a negative effect on the operation at the inlet side of a pump.
- How to properly maintain and troubleshoot the inlet side of a hydraulic pump.
- How to accurately troubleshoot problems at the inlet side of a pump.

The Bad-

Students will learn what is bad for a pump:

- The exact set of operating conditions relative to pump speed, inlet restriction, and temperature, that causes the dissolved air to come out of the oil and cause pump cavitation.
- Exactly what cavitation looks like.
- The negative effect cavitation has on the oil with respect to lubrication, sealing, heat dissipation, and cooling.
- The effect cavitation has on a hydraulic system's temperature, pressure, and flow.
- The noise caused by the “implosions” as the cavities come into contact with pressure at the outlet port of a pump.
- Symptoms of cavitation.
- Why air (aeration) getting into the inlet side of a pump is not cavitation.
- Why aeration caused by an air leak at the inlet side of a hydraulic pump is referred to as “pseudo-cavitation.”
- Why pseudo-cavitation is considerably more damaging to a hydraulic system than cavitation.
- Symptoms of pseudo-cavitation.



The Benefit to Industry-

Industry benefits because students know:

- How and why to determine a pump inlet restriction's “point-of-reference” or, normal inlet restriction.
- How a pump inlet restriction's “point-of-reference” is a vital link in averting unexpected and catastrophic pump failures.
- What diagnostic instruments are needed to maintain and troubleshoot the inlet side of a hydraulic pump.
- How to safely and correctly use these diagnostic instruments.
- Critical proactive maintenance procedures that must be performed at the inlet side of a pump.
- How to troubleshoot the inlet side of a hydraulic pump.

Distributed by
 Learning Labs, Inc.

1-800-334-4943
www.LLI.com

www.fpti.org

Hydraulic Training Systems

Teaching and learning hydraulics in real-time

MF200-CAV Pump Cavitation Simulator

A Teaching and Learning Masterpiece-

This exceptional simulator is a teaching and learning masterpiece because it leaves absolutely nothing to the imagination because it can simulate every situation in real time:

- Normal operation at the inlet side of a pump- students will see with a vacuum gauge, flow meter, pressure gauge, and temperature gauge exactly how a well-designed and maintained pump inlet works.
- High inlet restriction – as you operate the “oil-restrictor” valve students will see the pump inlet restriction gradually climbing until the dissolved air comes out of the oil and the pressure causes the loud implosions.
- Low inlet restriction – as you lower the oil level in real time the students see what happens when air enters the inlet side of the pump. They will see the oil begin to foam in the reservoir and in the transmission lines as the now semi-filled oil pump/air compressor pumps harmful air into the system.

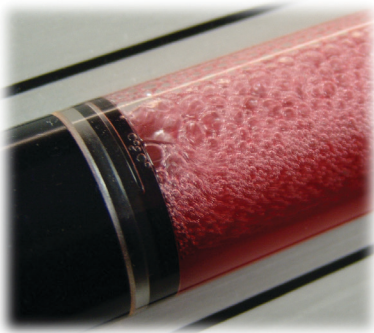

*Demonstrate cavitation and pseudo-cavitation
- Occurs when inlet is restricted or when there is an air leak present*

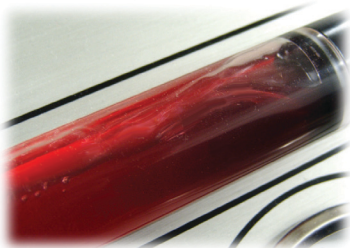

*Demonstrate Laminar Flow -
Occurs when air enters the oil flow*

- Oil return lines now become exposed – as the oil level continues to drop, the oil return line that was once below the oil level is now pumping oil in above the oil level.

Students will witness what they will probably never witness again: the violent turbulence that is caused as the discharge flow begins to churn up the oil in the reservoir and cause it to foam.

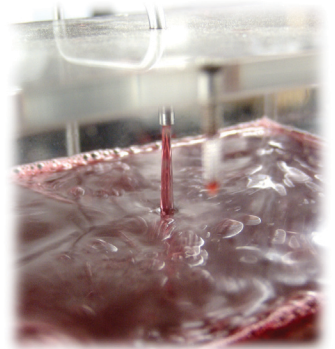

*Demonstrate turbulence -
Caused by oil discharging
above surface*

- Vortex begins – a further drop in the oil level makes it encroach on the opening in the pump inlet transmission line.

Students will again witness a situation they will only have witnessed when emptying a bathtub or a sink: the swirling motion of the oil as it enters the pump's inlet transmission line, and then the “explosion” as the air and oil return to the reservoir “blows” through the oil to the surface.

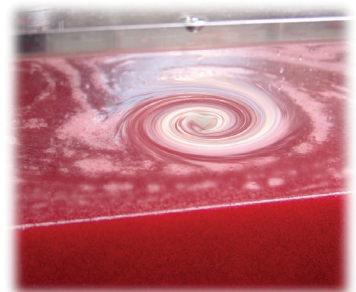

*Demonstrate vortex -
Occurs when oil levels are neglected or
because of poor design*

It's truly an experience the students will never forget – and isn't that really the point?

Hydraulic Training Systems

Teaching and learning hydraulics in real-time

MF200-CAV Pump Cavitation Simulator

The MF200-CAV consists of:

- Extremely attractive aesthetic design suitable for classroom or lab use. Ideally sized for instructor led group activities.
- Transparent components include: oil reservoir; pump inlet transmission line; and pump outlet transmission line.
- Lighting: all transparent components have backlighting to increase visual effects.
- Controls (panel-mounted): pump inlet restrictor valve (adjustable); air inlet valve (adjustable); pressure control valve (adjustable); pump inlet opening in reservoir (height adjustable).
- Diagnostic instruments (panel-mounted): flowmeter 7.6 Lpm (0-2.0 GPM); vacuum gauge 75cm (0-30") Hg (mercury), 10cm (4") glycerine-filled, Bourdon tube type; pressure gauge 41 bar (0-600 PSI), 10cm (4") glycerine-filled, Bourdon tube type; dual-scale temperature gauge, digital, oil and ambient temperatures.
- Pump: fixed-displacement external gear type, 6.8 Lpm (1.8 GPM).
- *Electric motor: 1 HP TEFC, 1800 RPM; 115V single-phase; 15 amps.
- On/off switch, panel-mounted, with light and thermal overload protection.
- Pre-set safety pressure relief valve.
- Reservoir - Transparent with baffle, oil filler/breather cap.
- Reservoir capacity: 17 liters (4.5 gallons).
- Oil filter: return-line w/bypass valve; spin on/off; 10 micron.
- Steel and aluminum construction.
- All parts finished with durable powder coat.
- Heavy-duty storage shelf.
- Four (4) wheel, medium-duty swivel casters w/brakes.

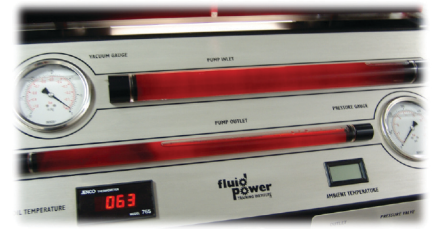

Transparent, back-lit suction & pressure lines

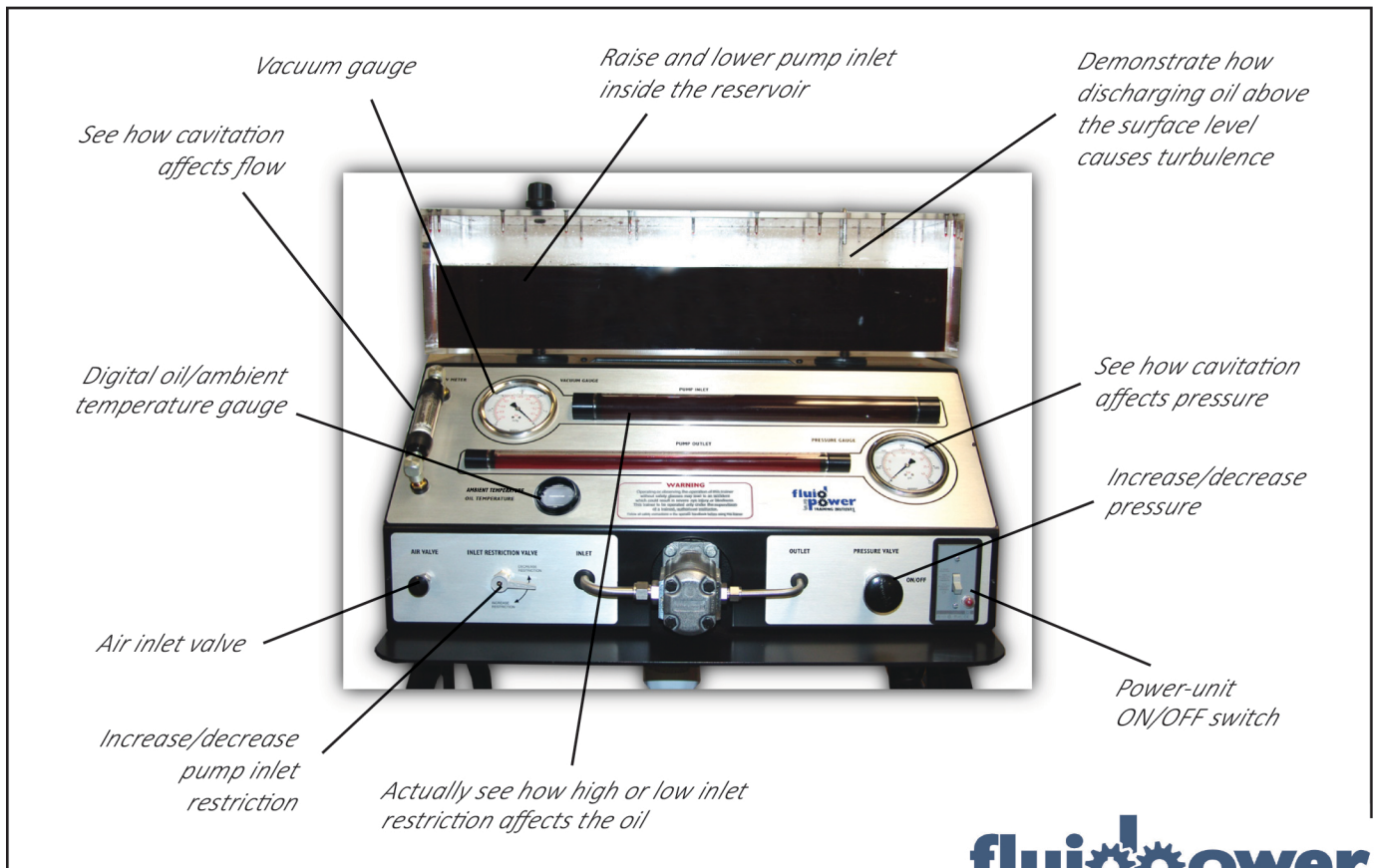

*All FPTI™ simulators are available for operation at any voltage or frequency

Hydraulic Training Systems

Teaching and learning hydraulics in real-time

MF200-CAV Pump Cavitation Simulator

Course Materials and Visual Aids -

- Manual - Operation at the Inlet Side of a Pump (includes laboratory activities)
- Instructor's guide and answer sheets
- Visual Presentation - Operation at the Inlet Side of a Pump. Full-color, PowerPoint presentation in CD format
- Student workbook featuring trainer activities

Shipping Specifications -

Shipping weight
(does not include pallet and packaging):
84 kgs (185 lbs)

Shipping dimensions:

145 cm (57") T x 76 cm (30") W x 51 cm (20") D

Warranty -

FPTI™ warrants its products against defect in materials or workmanship for a period of two (2) years from date of delivery.

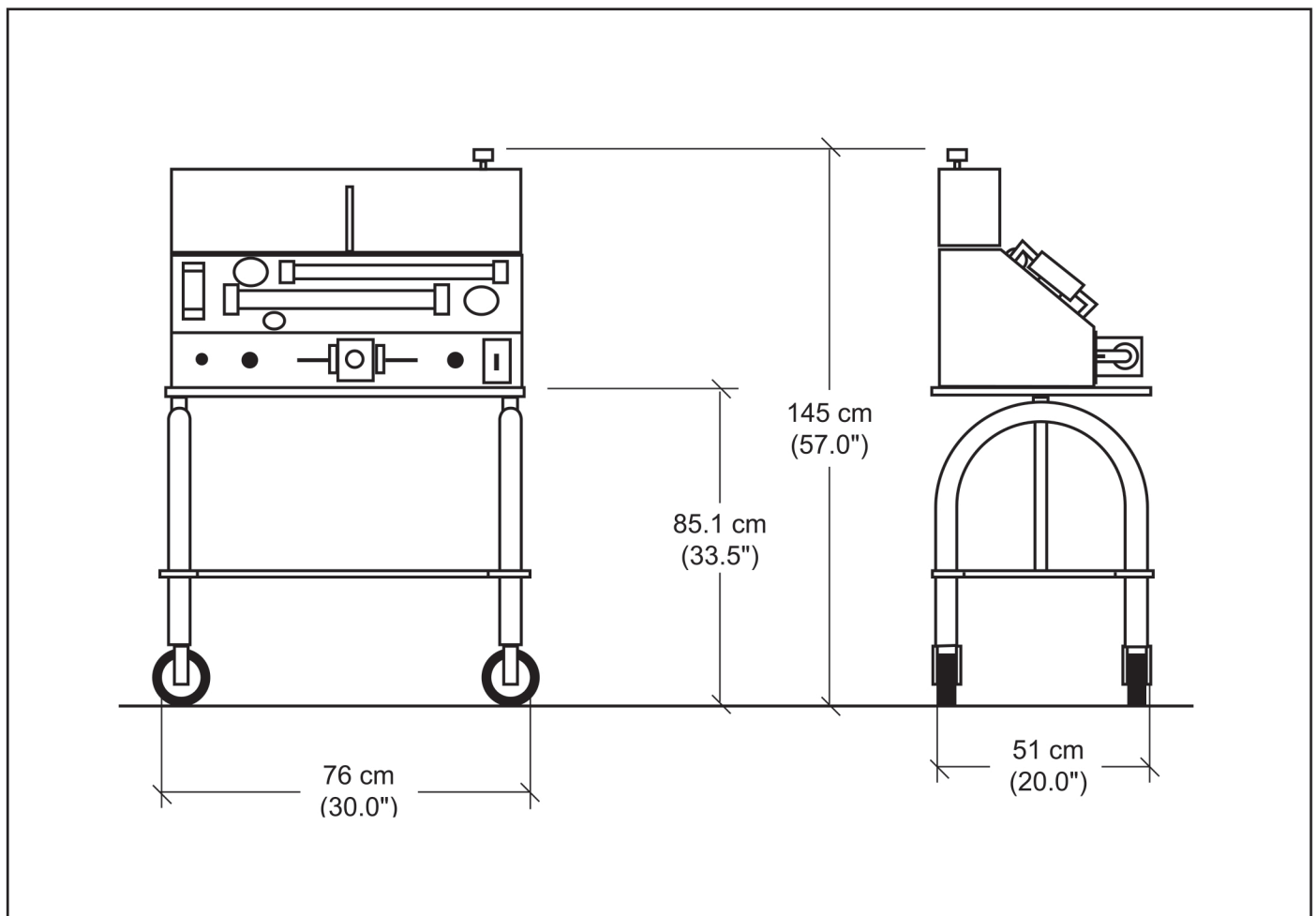

Distributed by

 Learning Labs, Inc.

1-800-334-4943

www.LLI.com

fluidpower
TRAINING INSTITUTE™
www.fpti.org