

Hydraulic Training Systems

Teaching and learning hydraulics in real-time



MF400-HCTS Hydraulic Cylinder Training Simulator -

Purpose-

The MF400-HCTS is designed to help instructors teach and students learn how to safely and correctly perform the following skills:

- Overhaul a hydraulic cylinder.
- Identify and use the tools needed to overhaul a hydraulic cylinder.
- Inspect the components in a hydraulic cylinder to determine root cause of failure.
- Replace piston and gland seals.
- Test a hydraulic cylinder.
- Air bleed a hydraulic cylinder.

How the MF400-HCTS will benefit instructors, students and the college:

1. Instructors will benefit because they will:

- Teach a cylinder overhaul course with materials that were developed by cylinder overhaul specialists.
- Teach overhaul techniques that are based on best industry practices that foster safety and efficiency in the lab and ultimately in the work-place.
- Teach need-to-know information – cylinder defects are consistent with the most common causes of cylinder failure.
- Efficient simulator design makes good use of valuable lab space while creating a safe and meaningful learning environment.

2. Students will benefit because they will:

- Have skills that enable them to overhaul hydraulic cylinders safely and efficiently.
- Have the skills needed to correctly analyze root causes of cylinder failure and remedy them.
- Have skills that will set them apart from others when applying for jobs. Their unique abilities will afford them higher wages and long-term employment.
- Be empowered not only to work safely themselves but also to promote a safe working environment.
- Be an asset to their respective companies because their skills will increase productivity and profitability.
- They will avoid safety hazards caused by trial and error cylinder overhaul practices.



3. Colleges will benefit because they will:

- Attract students because students will see and appreciate the investment the college has made in lab equipment that is specifically designed for teaching skills safely.
- Graduate students who will have the skill-sets needed to get, and keep, good paying jobs.
- Serve industry well – properly trained technicians means increased productivity and profitability for employers.
- Invest in training simulators that are designed for teaching specific skills safely leaving less chance for accidents and thus reducing liability.

Distributed by

 Learning Labs, Inc.

1-800-334-4943
www.LLI.com

www.fpti.org

Hydraulic Training Systems

Teaching and learning hydraulics in real-time

MF400-HCTS Hydraulic Cylinder Training Simulator -

Hands-on Activities -

Hands-on activities include:

- Steps on preparing a cylinder for service – removing, draining the oil, and securing it so it cannot move.
- Tools - selection and safe and proper use.
- Correct disassembly procedures.
- Component inspection and failure analysis.
- When to hone a cylinder tube.
- Correct procedures for installing piston seals and rod seals.
- Correct assembly procedures.
- Correct test procedures.
- Correct installation and air-bleeding procedures.

Course material and Visual Aids -

- Student manual – How to Service Hydraulic Cylinders – a guide for beginners.

The MF400-HCTS consists of the following components:

- Four-station mobile training module equipped with (4) swivel-lock casters. Steel and aluminum construction with powder coat finish.
- Welded steel anchors and cradles with mechanical locks to secure the cylinders for safety and handling.
- Four (4) clear acrylic, cylinder safety covers at each cylinder station to protect the student from oil spray in the event they did not reassemble the cylinder, or install the seals, correctly.
- Can store up to eighteen (18) hydraulic cylinders (available for purchase separately).

<u>CYLINDER TYPE</u>	<u>PART #</u>
<i>Round-weld type hydraulic cylinder</i>	MF400-RWC
<i>Tie-rod type hydraulic cylinder</i>	MF400-TRC

The MF400-HCTS teaches students, in addition to proper and safe cylinder overhaul procedures, how to correctly analyze the most common types of cylinder failures – in real time.

- Safe and ergonomic cylinder fixture design. Cylinders are anchored and secured in fixtures to prevent:
 - Barrel rotation while tightening/loosening rod glands.
 - Rod rotation while tightening/loosening piston retaining nuts.
 - Inadvertent cylinder movement/falling prevents the potential for leg/foot injuries.

Warranty -

As with all FPTI™ training systems, the MF400-HCTS Hydraulic Training Simulator is covered for two (2) years from date of delivery.

Warranty covers defects in materials and quality of work. Warranty does not cover damage caused by abuse or modifications.

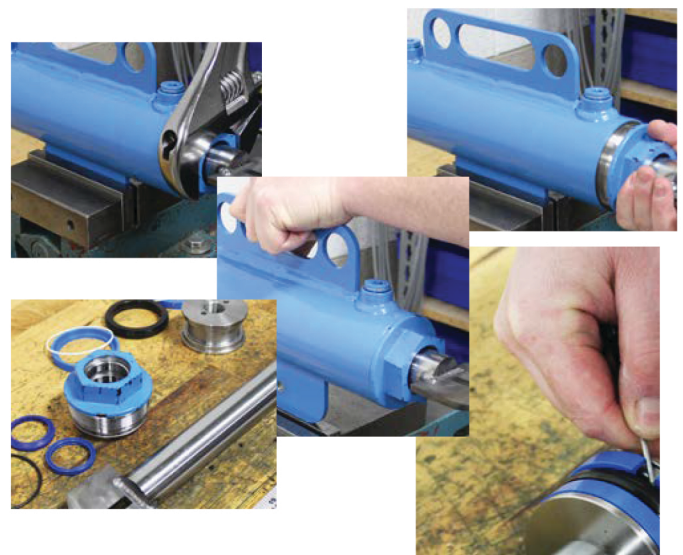

Hydraulic Training Systems

Teaching and learning hydraulics in real-time

MF400-HCTS Hydraulic Cylinder Training Simulator -

Shipping Specifications -

Shipping weight:
(does not include pallet and packaging)

825 lbs (374 kgs)

Shipping dimensions:
(includes pallet and packaging)

84" (213cm) Tall X 54" (137cm) Wide X 42" (107cm) Deep

Warranty -

FPTI™ warrants its products against defect in materials and/or workmanship for a period of two (2) years from date of delivery.

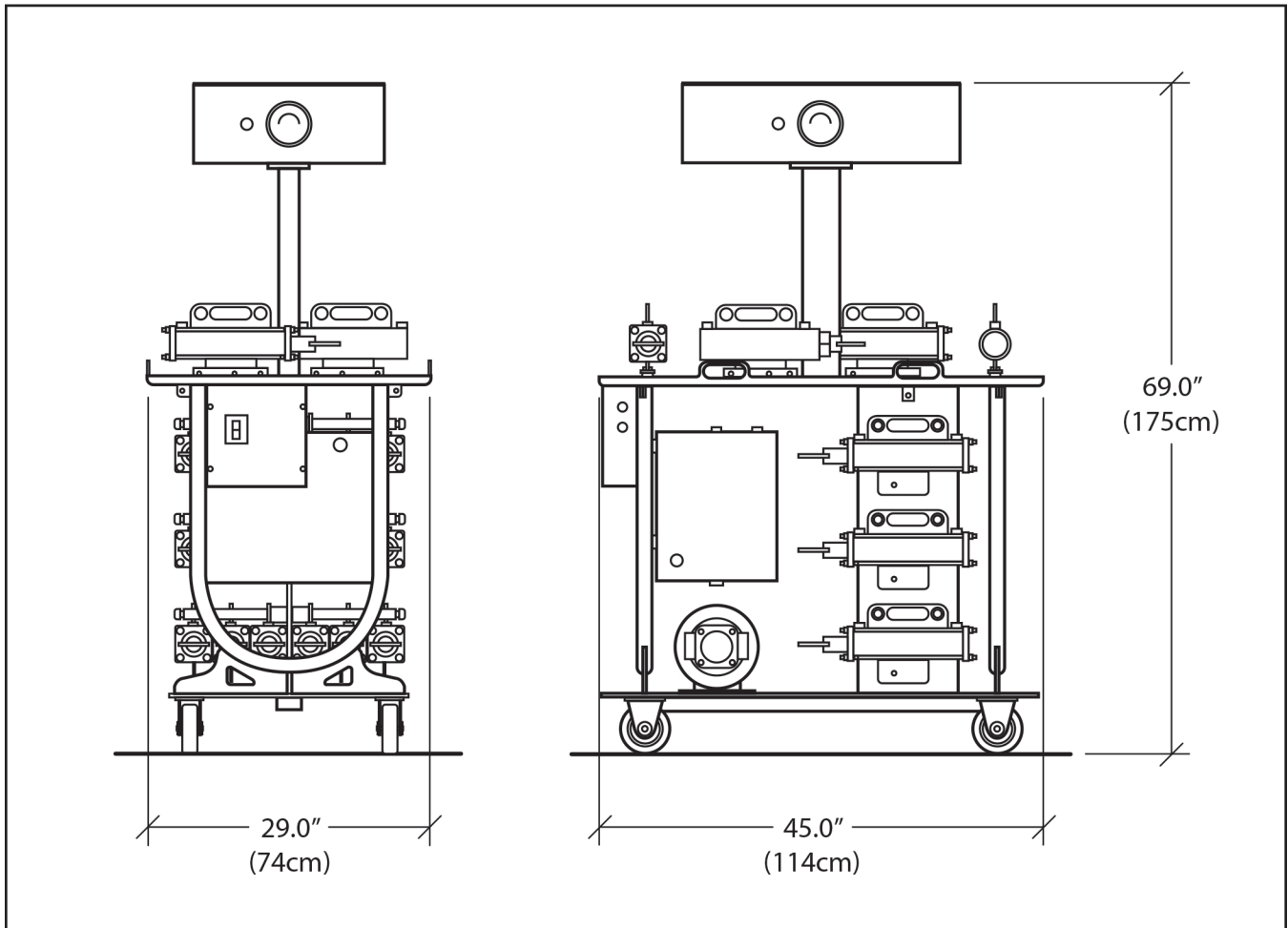

Distributed by

 Learning Labs, Inc.

1-800-334-4943
www.LLI.com

www.fpti.org